



# Dual Agilex Computational Storage Module

## Product Brief (AGF-CS-PCIe)

### Key Features

- PCIe add-on card compliant to PCI-SIG, PCI Express Specifications Revision 4.0
- 3/4 length, full height, double-wide [Length 266.7mm, height 111.15mm, double-width 39mm (34.8mm primary, 2.67 secondary)]
- Two high performance Agilex F-Series O27 FPGA processing nodes with two P-Tiles and one E-Tile
- Support for up to eight on-board Gen4 M.2 NVMe SSDs
- PCIe Gen4 switch interconnect for the two FPGA nodes, 8x Gen4 M.2 NVMe SSDs and x16 Gen4 host PCIe edge connector
- 2 banks of 64-bit DDR4 memory (8GB/16GB) for each FPGA node
- Up to 300W card load with 75W from the PCIe edge connector and 225W from the auxiliary 8-pin CPU/GPU (EPS) connector
- Integrated USB Blaster II, Agilex debug and module monitor interfaces through a single micro-USB connector on PCIe bracket
- Extensive power, voltage and temperature telemetry with SMBus based access for host server board management controller (BMC)
- Optional Firefly interface for Networking interface



*Highest performance PCIe Computational Storage accelerator card with dual Intel 10nm Agilex FPGAs. Only module with up to 32/64TB on-board NVMe storage coupled with high performance FPGA processing nodes and Gen4 PCIe switch interconnect.*

### Target Applications

- Designed for high performance computation and store acceleration workloads
- Machine learning, AI inference,
- Big Data Analytics, Database Acceleration

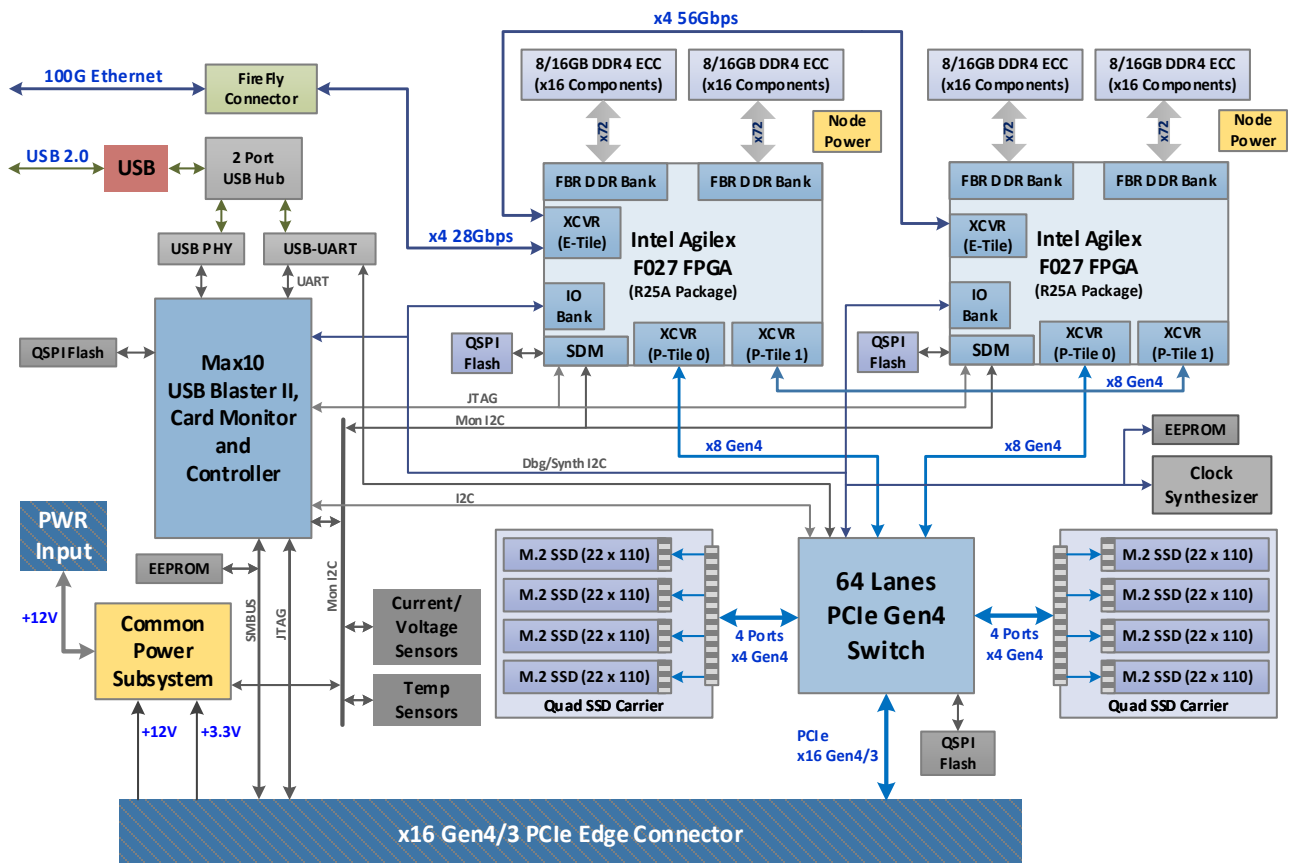

## On-board Development and Debug Support

- Integrated USB BlasterII
- UART access to the FPGA and module control CPLD
- Temperature, voltage and current monitoring sensors to module control CPLD
- Module input power measurement for profiling and verification in target servers/environment
- Automatic over-temp FPGA de-configuration
  - Multiple on-board diagnostic and status LEDs

### For sales or more information:



Hitek Systems LLC  
Phone: +1-301-528-8074  
Email: [sales@hiteksys.com](mailto:sales@hiteksys.com)